

Reliable Asphalt Products

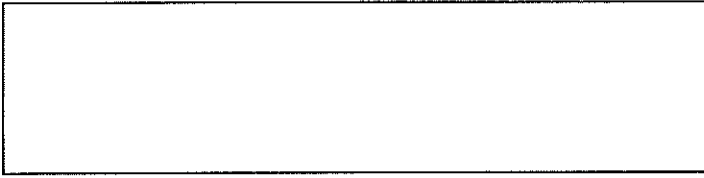

CHAIN WORKSHEET

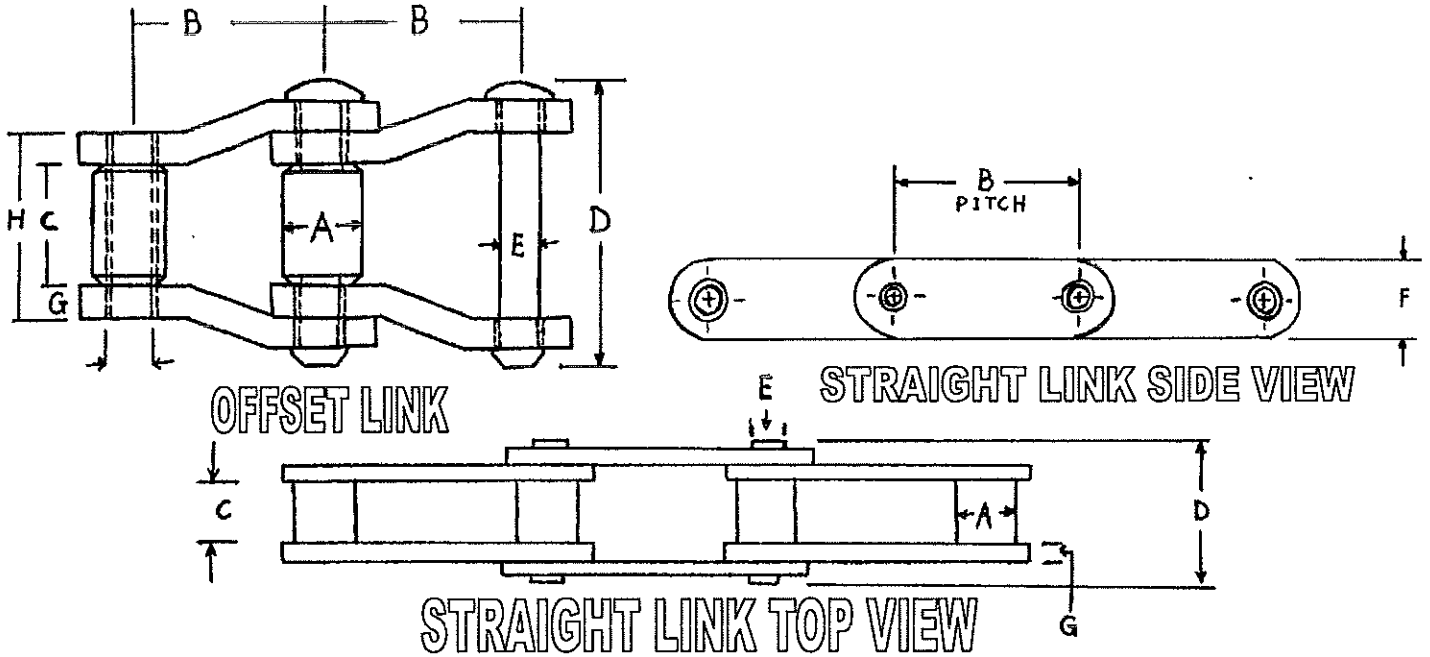

CHAIN TYPE: OR CHAIN NUMBER:

- ENGINEERED ROLLER
- CAST
- STEEL BUSHED

A. _____ B. _____ C. _____ D. _____ E. _____ F. _____ G. _____ H. _____

In order to establish the current chain type and style that you are using, please fill in as much information as possible. Please fax back to us, and we'll establish the appropriate chain, and give you a quotation on the best possible quality of the chain that best suits your needs.

Please call us if you have any questions, and as part of our normal excellent service, we'll work with you to reduce the overall costs of operating your plant.

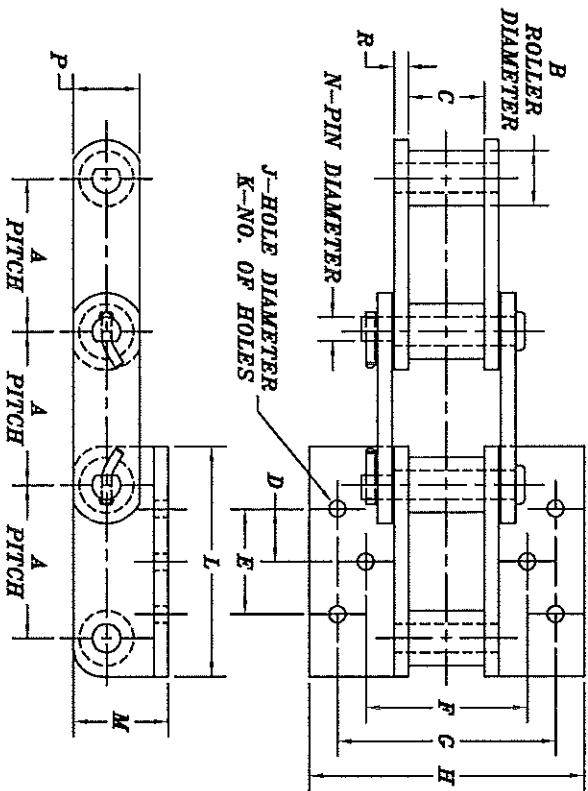

A	D	G	K	N
B	E	H	L	P
C	F	J	M	R

CHECK ONE: CHAIN IS ROLLER OR NON-ROLLER TYPE
 CHECK ONE: CHAIN IS STRAIGHT OR OFFSET TYPE

quantity: _____
 completed by: _____
 date: _____
 CHAIN NUMBER _____

REV	BY	DATE	DESCRIPTION
			TOLERANCES UNLESS OTHERWISE NOTED
			WHOLE NUMBER DIM. 1/16"
			FRACTIONAL DIM. 1/32"
			ANGULAR DIM. CDS 1/2°
			DECIMAL DIM. CDS .005
			2-1/2°
			3.00
			4.00

NOTICE: THE INFORMATION CONTAINED HEREIN IS PROPRIETARY TO RELIABLE ASPHALT PRODUCTS AND SHALL NOT BE REPRODUCED OR DISCLOSED IN WHOLE OR IN PART, NOR USED FOR ANY DESIGN OR MANUFACTURING PURPOSE UNLESS AUTHORIZED IN WRITING BY RELIABLE ASPHALT PRODUCTS.

Reliable **INC.** **Asphalt** **Products**

P.O. Box 519
 Phone: (502) 647-1782

Shelbyville KY 40066
 Fax: (502) 647-1786

SCALE: NONE	APPROVED BY:	DRAWN BY: Todd
JOB:	DATE: 11/21/05	DRAWING NUMBER:

CHAIN WITH 6 BOLT ATTACHMENT
 CUS TOMER FILL IN
 RAP STANDARD

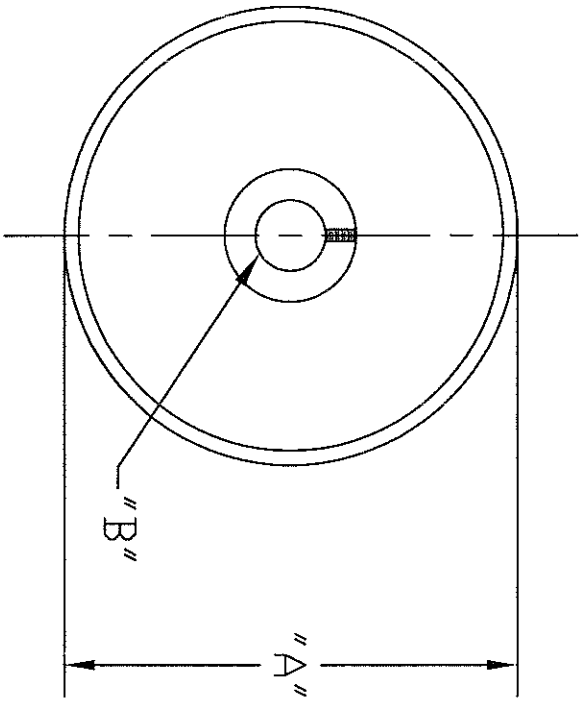

A- _____ D.D.
 B- _____ BORE
 C- _____ FACE WIDTH

quantity: _____
 completed by: _____
 date: _____

REV	BY	DATE	DESCRIPTION
			TOLERANCES UNLESS OTHERWISE NOTED
			UNLESS OTHERWISE SPECIFIED
			FUNCTIONAL DIM. 4/AS
			DECIMAL DIM. CXXX
			ANGLES 41/2°
			AND 3/16°
			UNLESS OTHERWISE SPECIFIED

NOTICE: THE INFORMATION CONTAINED HEREIN IS PROPRIETARY TO RELIABLE ASPHALT PRODUCTS. THIS DRAWING IS NOT TO BE REPRODUCED OR TRANSMITTED IN ANY FORM OR BY ANY MEANS, ELECTRONIC OR MECHANICAL, INCLUDING PHOTOCOPYING, RECORDING, OR BY ANY INFORMATION STORAGE AND RETRIEVAL SYSTEM, WITHOUT THE WRITTEN PERMISSION OF RELIABLE ASPHALT PRODUCTS.

Reliable
INC.

P.O. Box 519
Phone: (502) 647-1782

Asphalt
Products

Shelbyville KY 40066
Fax: (502) 647-1786

SCALE NONE	APPROVED BY:	DRAWN BY: Todd
JOB: FILL IN		DATE: 6/1/06
WHEEL		
CUSTOMER		
RAP STANDARD		
	DRAWING NUMBER	IDLER WHEEL

"B" - NO. OF TEETH

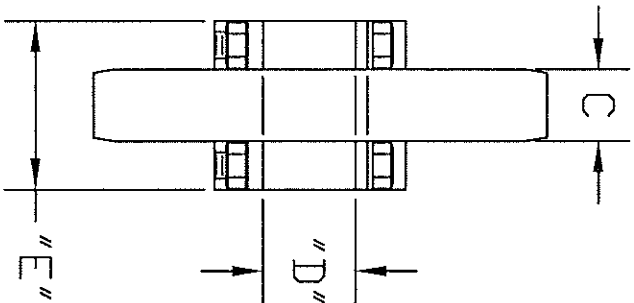
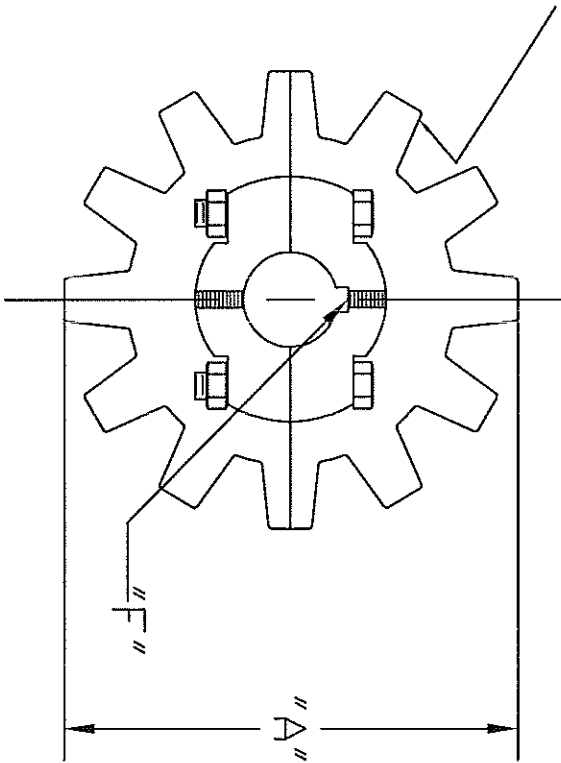

A- _____ O.D. OF SPROCKET E- _____ THRU BORE

B- _____ NUMBER OF TEETH F- _____ KEYWAY

C- _____ THICKNESS G- CHAIN NUMBER AND BRAND _____

D- _____ BORE

quantity: _____

completed by: _____

date: _____

REV	BY	DATE	DESCRIPTION
			QUOTATIONS DRESS ORDERED
			WHOLE NUMBER DIM 14/16
			FRACTIONAL DIM 14/16
			ANGULAR DIM C90
			DECIMAL DIM C90
			C90
			14/2
			4.00
			4.005

NOTICE: THE INFORMATION CONTAINED HEREIN IS PROPRIETARY TO RELIABLE ASPHALT PRODUCTS. PART AND DESIGN ARE NOT TO BE REPRODUCED OR DISTRIBUTED IN WHOLE OR IN PART AND USED FOR ANY DESIGN OR MANUFACTURING PURPOSES UNLESS AUTHORIZED IN WRITING BY RELIABLE ASPHALT PRODUCTS.

Reliable  **Asphalt Products**

P.O. Box 519
 Phone: (502) 647-1782
 Shelbyville KY 40066
 Fax: (502) 647-1786

SCALE NONE
 JOB FILL IN
 APPROVED BY
 DRAWN BY Todd
 DATE 6/1/06

SPLIT SPROCKET
CUSTOMER "FILL IN"
RAP STANDARD

DRAWING NUMBER
 SPLIT SPROCKET

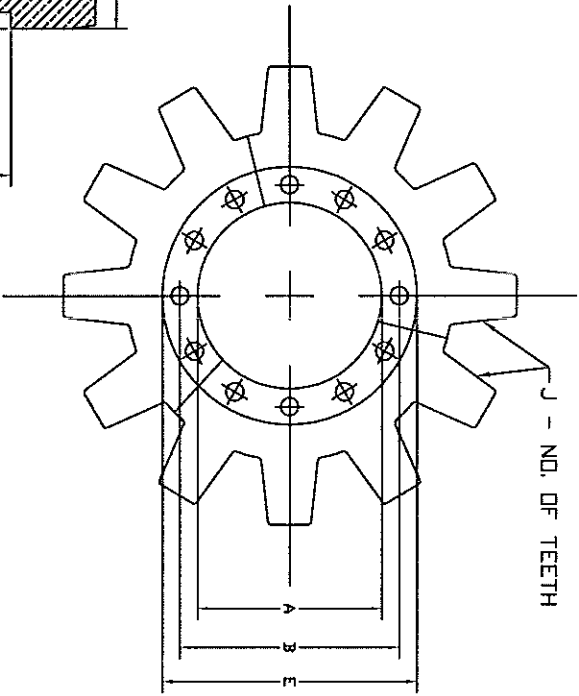

J - NO. OF TEETH

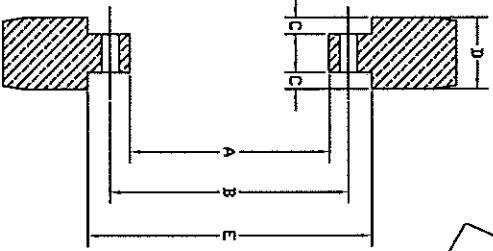

1 1T-STYLE

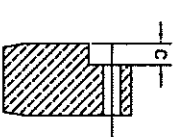

2 1L-STYLE

- A- _____ INSIDE BORE
 - B- _____ BOLT CIRCLE
 - C- _____ 1T-STYLE
 - C- _____ 1L-STYLE
 - D- _____ THICKNESS
 - E- _____ SHOULDER
 - F- _____ DIA. _____ BOLT _____ HOLE (CHECK ONE)
 - G- _____ NUMBER OF HOLES
 - H- ARE HOLES EQUALLY SPACED? _____
 - J- NUMBER OF TEETH _____
 - K- CHAIN NUMBER AND BRAND _____
- quantity: _____
 completed by: _____
 date: _____

REV	BY	DATE	DESCRIPTION

TOLERANCES UNLESS OTHERWISE NOTED	ANGLE DIM. C90	24/2°
WHOLE NUMBER DIM.	±0.15°	±0.00
FRACTIONAL DIM.	±0.15°	±0.00
DECIMAL DIM. C0.00		±0.00

NOTICE: PRODUCTS AND SHALL NOT BE REPRODUCED OR DISCLOSED IN WHOLE OR IN PART, NOR USED FOR ANY DESIGN OR MANUFACTURING PURPOSES UNLESS AUTHORIZED IN WRITING BY RELIABLE ASPHALT PRODUCTS.

Reliable **Asphalt** **Products**

P.O. Box 519
 Phone: (502) 647-1782
 Shelbyville KY 40066
 Fax: (502) 647-1786

SCALE: NONE
 JOB: FILL IN
 APPROVED BY: _____
 DRAWN BY: Todd
 DATE: 10/25/05

SEGMENTED "SPROCKET" CUSTOMER FILL IN
RAP STANDARD

DRAWING NUMBER: _____
 SEGMENTED: SPROCKET

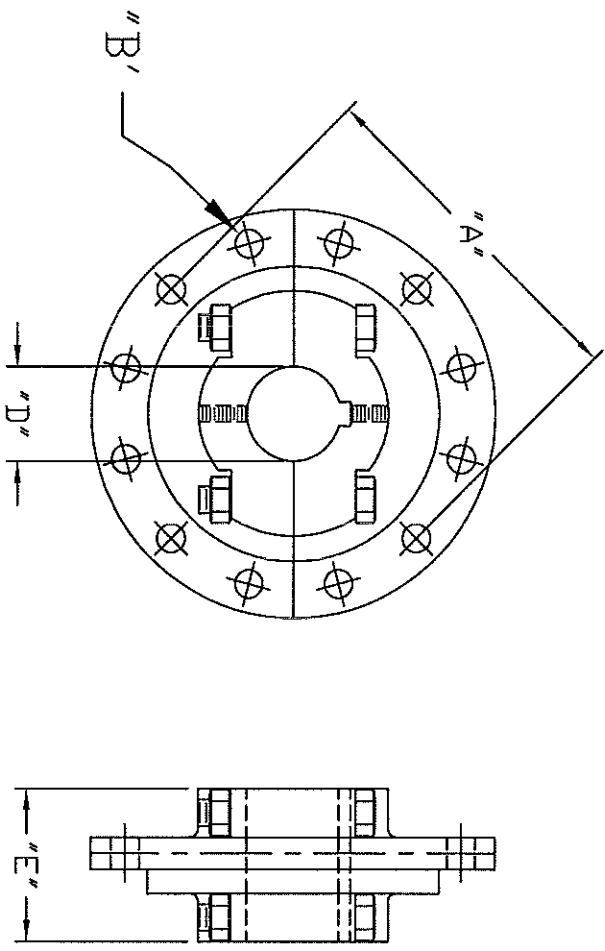

A- _____ BOLT CIRCLE DIAMETER
 B- _____ BOLT HOLE DIAMETER
 C- _____ NUMBER OF BOLT HOLES
 D- _____ BORE DIAMETER
 E- _____ THRU BORE LENGTH
 F- ARE HOLES EQUALLY SPACED? _____
 quantity: _____
 completed by: _____
 date: _____

REV	BY	DATE	DESCRIPTION
			PARALLEL UNLESS OTHERWISE NOTED
			VEHICLE NUMBER DIM. 41/16"
			FRONTAL DIM. 41/16"
			ANGULAR DIM. COO
			RECTANG. DIM. COO
			2 1/2" 2.00
			2.00

NOTICE: THE INFORMATION CONTAINED HEREIN IS PROPRIETARY TO RELIABLE ASPHALT PRODUCTS AND SHALL NOT BE REPRODUCED OR DISCLOSED IN WHOLE OR IN PART, NOR USED FOR ANY DESIGN OR MANUFACTURING PURPOSES UNLESS AUTHORIZED IN WRITING BY RELIABLE ASPHALT PRODUCTS.

Reliable
INC.
Asphalt
Products

P.O. Box 519
 Phone: (502) 647-1782
 Shelbyville KY 40066
 Fax: (502) 647-1786

SCALE: NONE
 JOB: FILL IN
 APPROVED BY: _____
 DRAWN BY: Todd
 DATE: 10/25/05
 DRAWING NUMBER: _____
 SPLIT: HUB

PIERCE
CUSTOMER "FILL IN"
RAP STANDARD

DIMENSIONS

"A" = _____
 "B" = _____
 "C" = _____

PATTERN STYLE:

"1" = _____ OR "2" = _____
 "X" = _____
 "Y" = _____
 "Z" = _____
 "HOLE" ϕ = _____

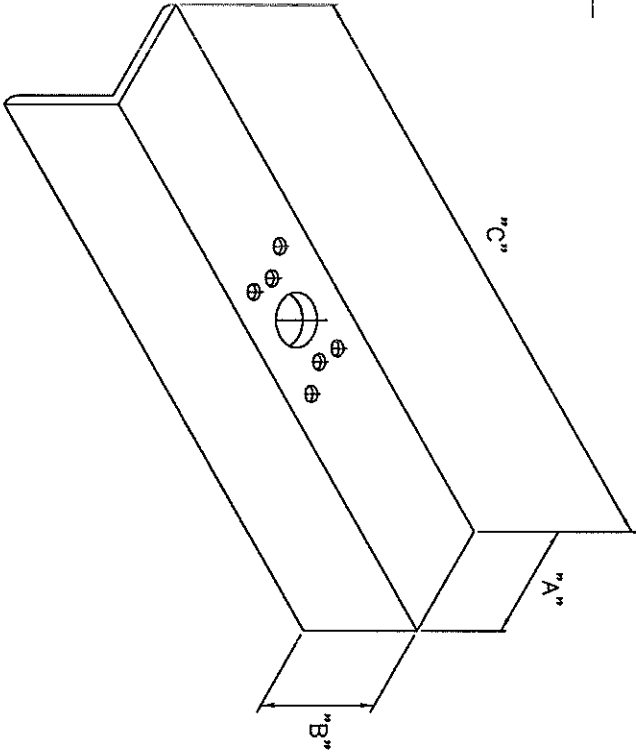

SLAT LAYOUT

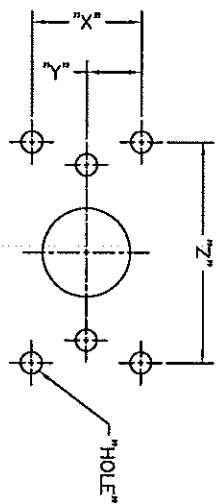

PATTERN #2
PUNCH STYLE

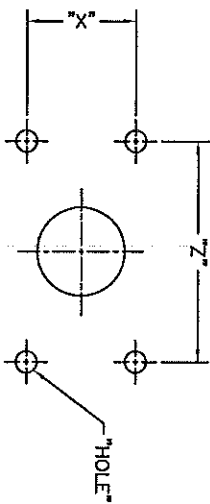

PATTERN #1
PUNCH STYLE

QUANTITY REQUIRED _____

completed by: _____
 date: _____

REV	BY	DATE	DESCRIPTION
1	MM	11/17	PRODUCTION ORDER SPECIFICATIONS
2	MM	11/17	REVISED SPECIFICATIONS
3	MM	11/17	REVISED SPECIFICATIONS

NOTICE: PART NOT TO BE USED FOR ANY DESIGN OR MANUFACTURING PURPOSE UNLESS AUTHORIZED IN WRITING BY RELIABLE ASPHALT PRODUCTS.

Reliable **ASPHALT** **Products**
INC.
 P.O. Box 519
 Phone: (502) 647-1782 Fax: (502) 647-1786
 Shelbyville KY 40066

SCALE: NONE APPROVED BY: _____
 DATE: 12/02/09

CUSTOMER SPECIFICATIONS
 DRAWING NUMBER: SLAT

DIMENSIONS

'A' = _____
 'B' = _____
 'C' = _____
 'D' = _____
 PATTERN STYLE:
 '1' _____ OR '2' _____
 'W' = _____
 'X' = _____
 'Y' = _____
 'Z' = _____
 'HOLE' ϕ = _____

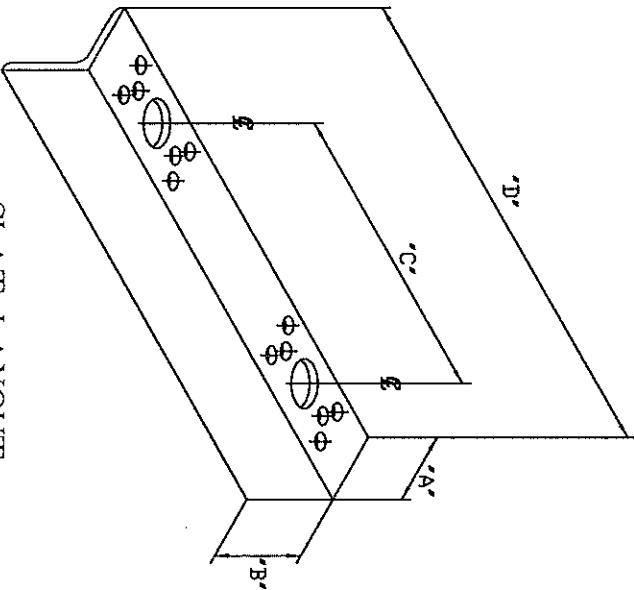

SLAT LAYOUT

completed by: _____
 date: _____

REV	BY	DATE	DESCRIPTION
			TOLERANCES UNLESS OTHERWISE NOTED
			ANGLE DIM. 1/16"
			FRACTIONAL DIM. 1/16"
			ANGULAR DIM. 1/16"
			DECIMAL DIM. 0.005
			31/2" 1/16"
			4.00 1/16"
			4.005 1/16"

NOTICE: THE INFORMATION CONTAINED HEREIN IS PROPRIETARY TO RELIABLE ASPHALT PRODUCTS AND SHALL NOT BE REPRODUCED OR DISCLOSED IN WHOLE OR IN PART, NOR USED FOR ANY DESIGN OR MANUFACTURING PURPOSE UNLESS AUTHORIZED IN WRITING BY RELIABLE ASPHALT PRODUCTS.

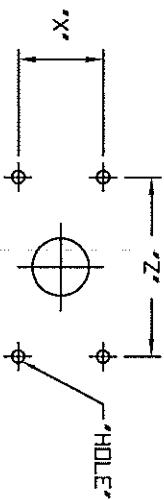
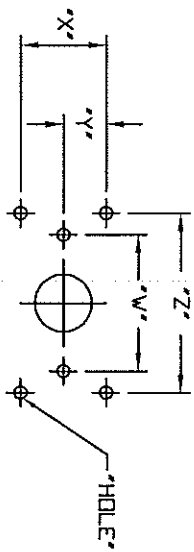

QUANTITY REQUIRED _____

Reliable
 P.O. Box 519
 Phone: (502) 647-1782

asphalt
 products
 Shelbyville KY 40066
 Fax: (502) 647-1786

SCALE NONE
 JOB FILL IN
 APPROVED BY: _____

DRAWN BY: Todd
 DATE: 6/01/06
 DRAWING NUMBER: _____

ANGLE STYLE SLAT
CUSTOMER FILL IN
RAP STANDARD

SLAT

DIMENSIONS

- 'A' = _____
 - 'B' = _____
 - 'C' = _____
 - 'D' = _____
 - 'E' = _____
 - 'F' = _____
- PATTERN STYLE
- '1' _____ OR '2' _____
 - 'X' = _____
 - 'Y' = _____
 - 'Z' = _____
 - 'HOLE' ϕ ' = _____

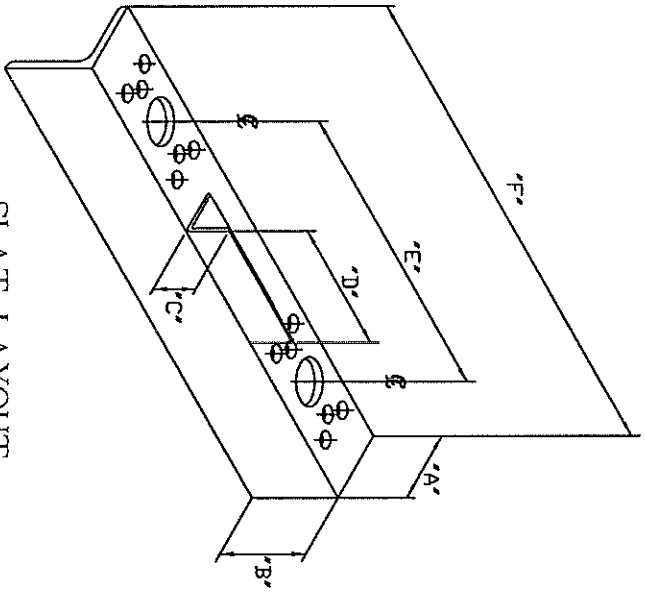

SLAT LAYOUT

completed by: _____
 date: _____

REV	BY	DATE	DESCRIPTION
			TOLERANCES UNLESS OTHERWISE NOTED
			ANGLE DIM. 30/30
			ANGULAR DIM. 30/30
			ARC DIM. 30/30
			LINE DIM. 30/30
			UNLESS OTHERWISE SPECIFIED
			ALL DIMENSIONS ARE IN INCHES
			DECIMALS ARE TO BE USED UNLESS OTHERWISE SPECIFIED
			ALL DIMENSIONS ARE TO BE TO UNLESS OTHERWISE SPECIFIED

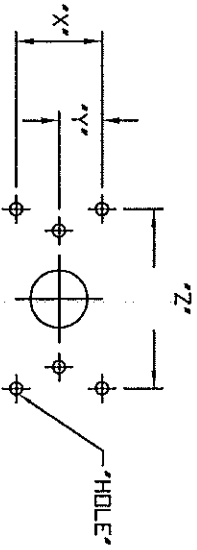

PATTERN #2
PUNCH STYLE

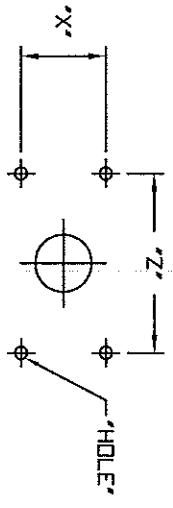

PATTERN #1
PUNCH STYLE

QUANTITY REQUIRED _____

Reliable **INC.** **Asphalt Products**

P.O. Box 519
 Phone: (502) 647-1782
 Fax: (502) 647-1786

Shelbyville KY 40066

DATE: 10/25/05

DRAWN BY: Todd

APPROVED BY: _____

SCALE: NONE

JOB: FILL IN

ANGLE STYLE SLAT W/ RISER

CUSTOMER SLAT WITH RISER

RAP STANDARD

DATE: 10/25/05

DRAWING NUMBER

SLAT WITH RISER

NOTICE: PRODUCTS AND SHALL NOT BE REPRODUCED OR DISCLOSED IN WHOLE OR IN PART, NOR USED FOR ANY DESIGN OR MANUFACTURING PURPOSES UNLESS AUTHORIZED IN WRITING BY RELIABLE ASPHALT PRODUCTS.